

## Big bag emptier SSS2

Robust and flexible construction.

Article number: P-500700

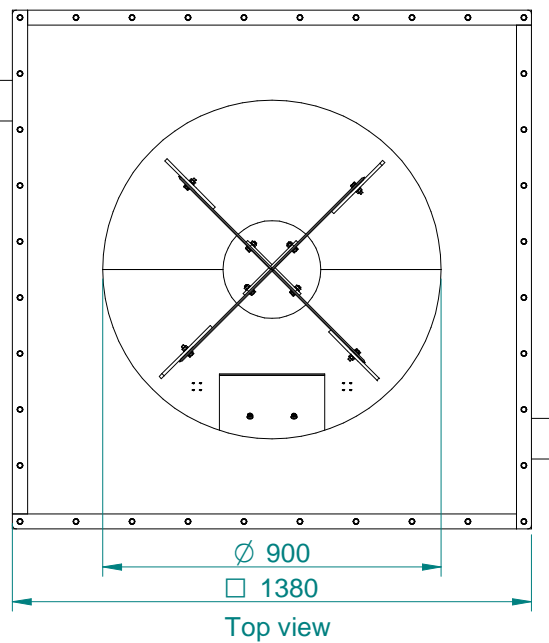
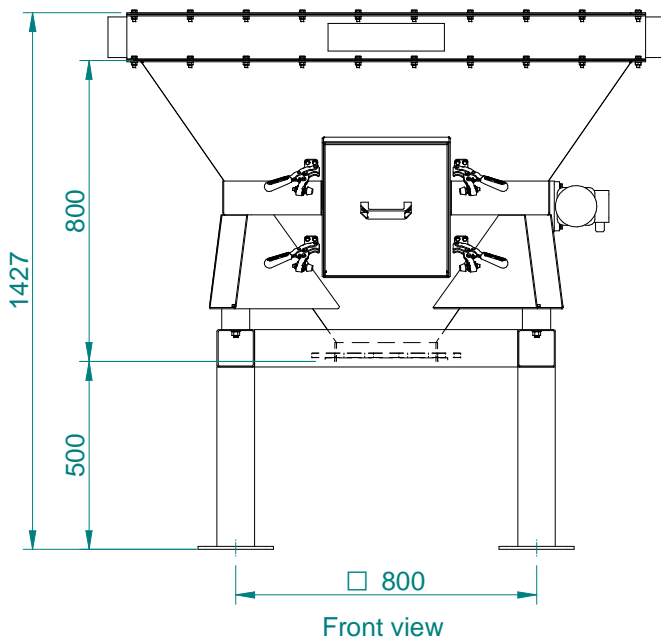

## Function

The big bag emptier is a single bag emptier where the big bag, with a suitable lifting aid, is lowered over the discharge cone. Here, the bag is cut open at the bottom with the help of a knife cross. The knife cross is adjustable and can be raised or lowered to adjust the size of the opening in the bag.

On the top side there is also a rubber cuff that forms tightly around the bag and thus prevents dusting.

## Standard equipment:

- Discharge cone with 55° descent angle
- Leg stand with vibration damper, 500mm free under outlet flange
- Vibrator MVE 200/3. 230/400 V, 50 Hz, 180W
- Outlet connection DN250 PN10
- Double rubber cuffs Ø900
- Hatch in discharge cone
- Manufactured in S355 and surface treated according to Scanmatic standard painting program BE00-002.

Options	Article number
Centering arms to fixate the bag	P-500702
Widened knife cross for wider cutting of the bag	P-500703
H-knife for alternative cutting of the big bag	P-500704
Fluidization	P-500709
Grating in the outlet	P-500712
Lifting yoke 500kg	P-500713
Lifting yoke 1500kg	P-500706
Lifting yoke 1500kg for lifting with forklift and telpher	P-500714
Bag suspension stand with lifting yoke 1500kg (P-500714)	P-500711
Telpher stand with telpher	P-500708
Greting plan with staircase	P-500710



The knife cross is removable and can easily be adjusted to increase or decrease the cutting of the bag.

