

### Kulventil 3-vägs

3-vägs kulventil i rostfritt stål. Ventilen kan manövreras manuellt eller förses med vriddon. Finns både som L och T-port.

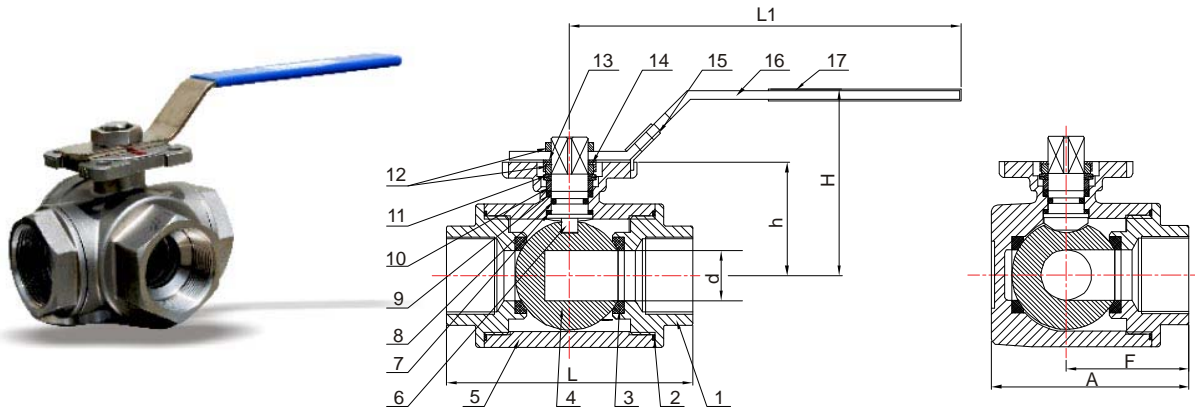

Storlek R	DN	d	L	H	H1	F	A	J	ISO5211 Topplatta	Moment (Nm)	Vikt (kg)	Artikelnummer T	Artikelnummer L
1/4"	8	9,5	75	66	130	37,5	57,5	9	F03/F04	8	0,70	P-10208008	P-10207008
3/8"	10	11	75	66	130	37,5	57,5	9	F03/F04	8	0,67	P-10208010	P-10207010
1/2"	15	12	75	66	130	37,5	57,5	9	F03/F04	8	0,73	P-10208015	P-10207015
3/4"	20	15	85	72	161	42,5	65,5	11	F04/F05	9	0,94	P-10208020	P-10207020
1"	25	20	100	77	161	50	79	11	F04/F05	15	1,38	P-10208025	P-10207025
1-1/4"	32	25	122	92	203	61	97	14	F05/F07	20	2,89	P-10208032	P-10207032
1-1/2"	40	32	131	96	203	65,5	106	14	F05/F07	30	3,60	P-10208040	P-10207040
2"	50	40	158	107	203	79	129	14	F05/F07	45	6,21	P-10208050	P-10207050
2-1/2"	65	49	178	135	254	101	167	17	F07/F10	50	8,72	P-10208065	P-10207065
3"	80	60	202	147	254	101	167	17	F07/F10	80	12,81	P-10208080	P-10207080
4"	100	75	246	160	310	123	203	17	F07/F10	110	21,60	P-10208100	P-10207100

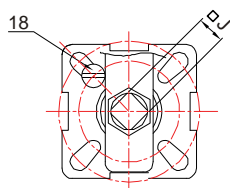
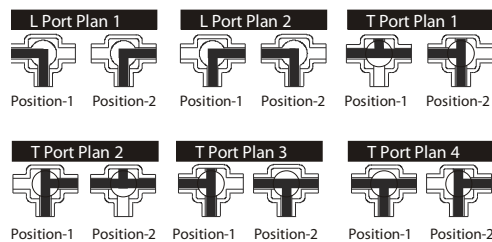

ISO5211 Topp platta

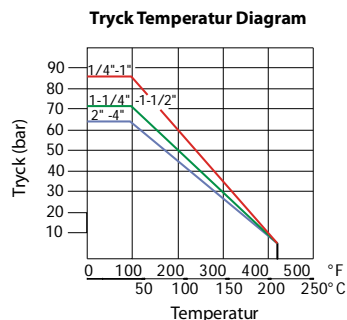

Nr.	Namn	Material
1	Ända	AISI316
2	Packning	PTFE
3	Säte	PTFE
4	Kula	AISI316
5	Hus	AISI316
6	Spindel	AISI316
7	Tryckbricka	PTFE
8	O-ring	Viton
9	Spindel tätning	PTFE
10	Spindel O-ring	AISI316
11	Tallriksfjäder	AISI301
12	Mutter	AISI301
13	Bricka	AISI301
14	Mutter låsning	AISI304
15	Låd anordning	AISI304
16	Handtag	AISI304
17	Överdrag handtag	Plastic
18	Stop skruv	AISI304