

Flänsad Kulventil

Kulventil i rostfritt stål med flänsanslutning. Ventilen kan manövreras manuellt eller förses med ett vriddon.
Finns i dimensioner från DN15 till DN 100

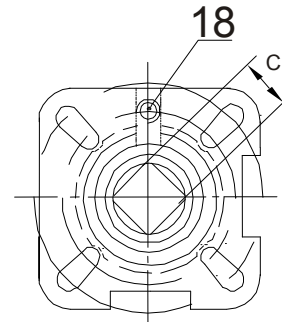

ISO5211 Topp platta

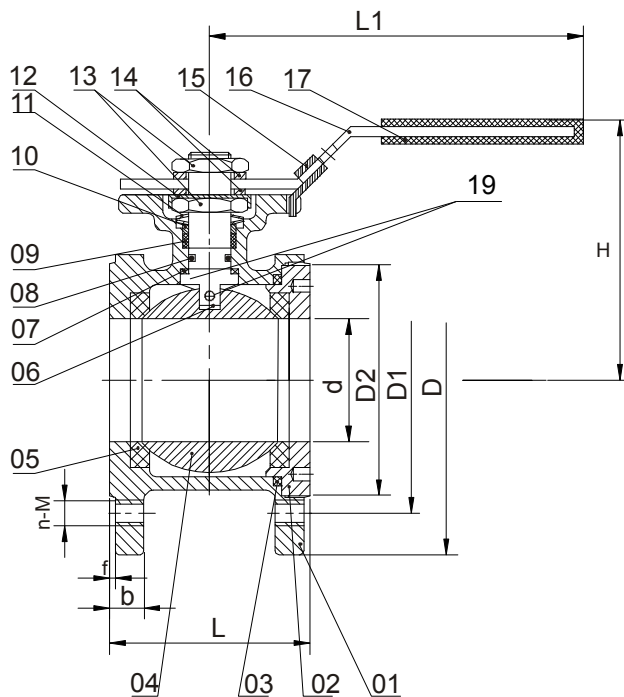

Nr.	Namn	Material
1	Hus	AISI316
2	Ända	AISI316
3	Tätning	PTFE
4	Kula	AISI316
5	Säte	R-PTFE(%15)
6	Spindel	AISI316
7	Bricka	PTFE
8	O-ring	Viton
9	Spindel säte	PTFE
10	Tätning	AISI304
11	Tallriksfjäder	AISI301
12	Låsmutter	AISI304
13	Mutter	AISI304
14	Bricka	AISI304
15	Låsanordning	AISI304
16	Handtag	AISI304
17	Överdrag handtag	Plast
18	Stopsprint	AISI304
19	Antistat anordning	AISI316

Storlek R DN	d	L	D	D1	D2	b	f	H	L1	C	ISO5211	n-M	Vridmoment (Nm)	Vikt (kg)	Artikel- nummer	
1/2"	15	15	36	95	65	45	12	2	70	115	9	F03	4-M12	5	1,11	P-10205015
3/4"	20	20	38	105	75	58	12	2	78	115	9	F03	4-M12	8	1,48	P-10205020
1"	25	25	50	115	85	68	12	2	90	160	11	F04/F05	4-M12	10	1,95	P-10205025
1-1/4"	32	32	53	140	100	78	14	2	100	160	11	F04/F05	4-M16	14	3,10	P-10205032
1-1/2"	40	40	65	150	110	88	15	3	105	200	14	F05/F07	4-M16	18	4,18	P-10205040
2"	50	50	78	165	125	102	16	3	125	200	14	F05/F07	4-M16	25	5,37	P-10205050
2-1/2"	65	65	98	185	145	122	16	3	140	255	17	F07/F10	4-M16	48	8,18	P-10205065
3"	80	76	118	200	160	138	18	3	145	255	17	F07/F10	4-M16	75	11,92	P-10205080
4"	100	94	140	220	180	158	18	3	175	300	17	F07/F10	4-M16	110	16,92	P-10205100