

Skjutspjäll

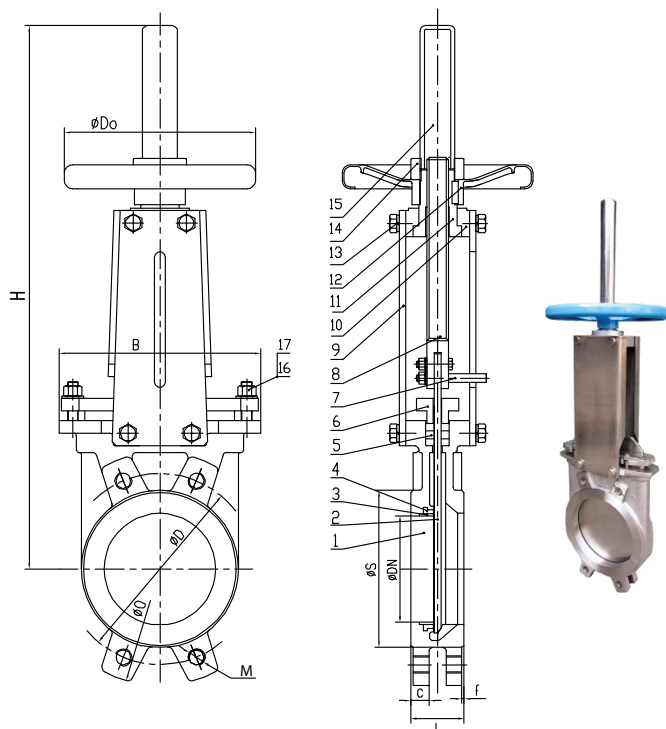

Sätetyper skjutspjäll

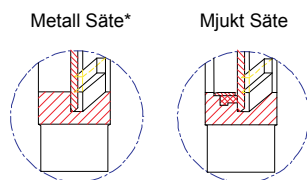

| Nr. | Namn | Material |
|-----|----------------------|----------------|
| 1 | Hus | GG25 |
| | | GGG40* |
| | | WCB |
| | | SS304 |
| | | SS316 |
| 2 | Skiva | SS304* |
| | | SS316 |
| 3 | Hållarring | 304/316 |
| 4 | Tätningring | EPDM |
| | | Viton |
| | | NBR |
| | | Metall* |
| 5 | Packning | PTFE + Silikon |
| 6 | Packning genomföring | GGG40/SS316 |
| 7 | Indikator | SS304 |
| 8 | Spindel | SS420/SS316 |
| 9 | Stödplattor | ASTM A36 |
| 10 | Stål block | ASTM A105 |
| 11 | Spindelmutter | ASTM B62 |
| 12 | Ratt | ASTM A126 |
| 13 | Bult | ASTM A193 B8 |
| 14 | Ratt överdrag | ASTM A105 |
| 15 | Skydd | ASTM A193 B8 |
| 16 | Bult | ASTM A193 B8 |
| 17 | Mutter | ASTM A194 8 |

Temperatur

| | |
|--------|-------|
| EPDM | 120°C |
| Viton | 180°C |
| NBR | 200°C |
| Metall | 450°C |

Dimensioner

| Storlek (DN) | L | ØO | ØD | S | C | f | B | H | ØDo | Fläns PN10 | | | Vikt (kg) | Artikel nummer |
|--------------|-----|-----|-----|-----|----|---|-----|------|-----|------------|----|---|-----------|----------------|
| | | | | | | | | | | M | ⊕ | ○ | | |
| 50 | 40 | 165 | 125 | 95 | 16 | 2 | 136 | 375 | 180 | M16 | 4 | - | 7 | P-111050 |
| 65 | 40 | 185 | 145 | 110 | 16 | 2 | 151 | 420 | 180 | M16 | 4 | - | 8 | P-111065 |
| 80 | 50 | 200 | 160 | 127 | 17 | 2 | 170 | 450 | 200 | M16 | 4 | 4 | 11 | P-111080 |
| 100 | 50 | 220 | 180 | 145 | 17 | 2 | 190 | 512 | 200 | M16 | 4 | 4 | 12 | P-111100 |
| 125 | 50 | 250 | 210 | 174 | 17 | 2 | 212 | 570 | 220 | M16 | 4 | 4 | 15 | P-111125 |
| 150 | 60 | 285 | 240 | 199 | 21 | 2 | 230 | 665 | 250 | M20 | 4 | 4 | 21 | P-111150 |
| 200 | 60 | 340 | 295 | 250 | 21 | 2 | 286 | 825 | 300 | M20 | 4 | 4 | 29 | P-111200 |
| 250 | 70 | 395 | 350 | 308 | 24 | 2 | 338 | 1000 | 350 | M20 | 8 | 4 | 46 | P-111250 |
| 300 | 70 | 445 | 400 | 360 | 24 | 2 | 388 | 1155 | 350 | M20 | 8 | 4 | 66 | P-111300 |
| 350 | 96 | 505 | 460 | 416 | 33 | 2 | 460 | 1310 | 400 | M20 | 12 | 4 | 92 | P-111350 |
| 400 | 100 | 565 | 515 | 466 | 35 | 2 | 520 | 1475 | 500 | M24 | 12 | 4 | 125 | P-111400 |
| 450 | 106 | 615 | 565 | 518 | 36 | 2 | 580 | 1660 | 500 | M24 | 16 | 4 | 180 | P-111450 |
| 500 | 110 | 670 | 620 | 572 | 37 | 2 | 620 | 1860 | 600 | M24 | 16 | 4 | 233 | P-111500 |
| 600 | 110 | 780 | 725 | 664 | 37 | 2 | 720 | 2150 | 700 | M27 | 16 | 4 | 320 | P-111600 |

* Angivet artikelnummer avser